

1	SHIELDING OF THE WORK AREA	
	WEIGHT (included in BASIC HOOD version)	
Version	Kg	lbs
5 mm Lead	215	474
10 mm Lead	390	860

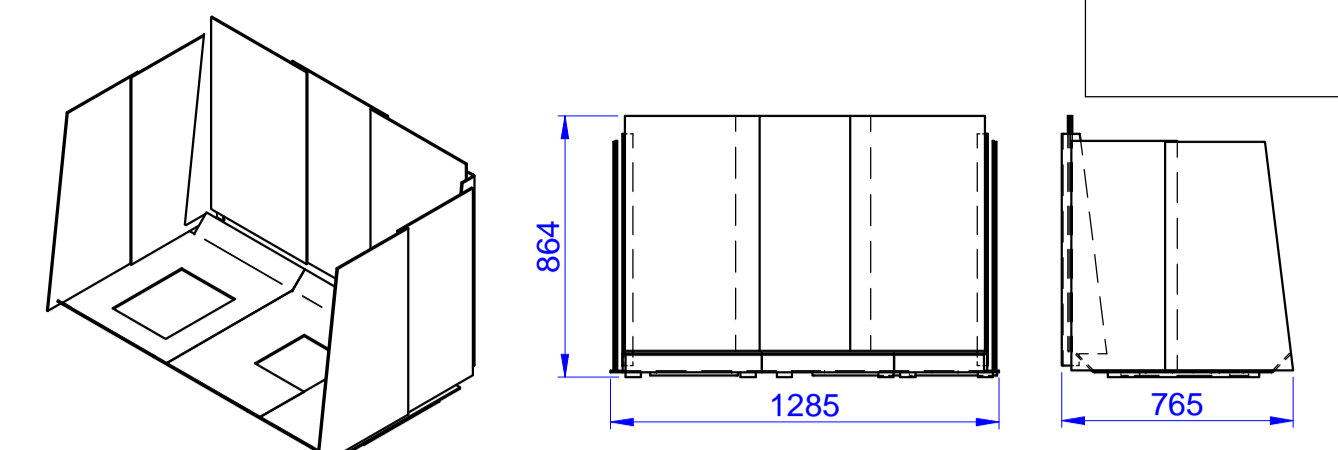

2	SHIELDED SLIDING GLASS	
	WEIGHT	
Version	Kg	lbs
5 mm equivalent Lead	20	44
10 mm equivalent Lead	30	66

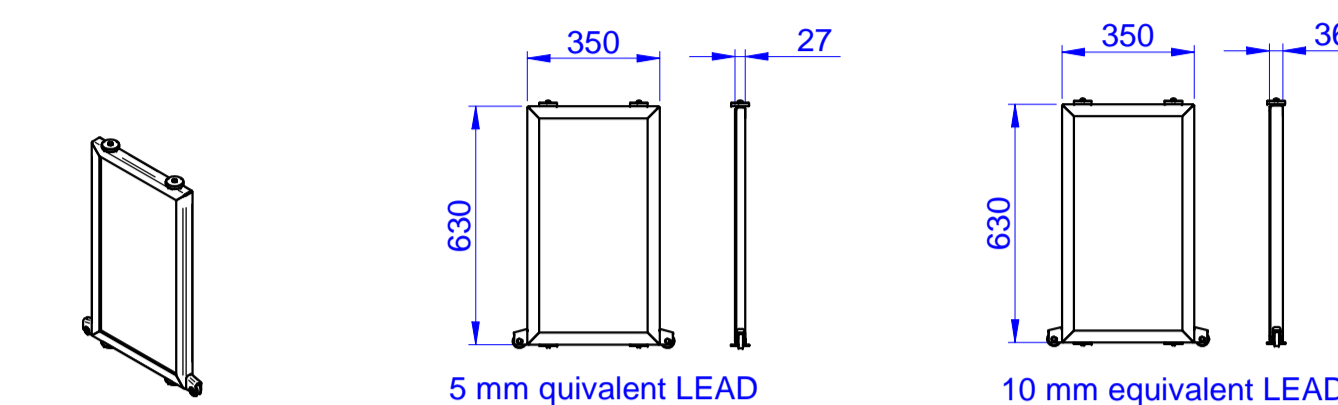

3	GENERATORS COMPARTMENT	
	WEIGHT	
Version	Kg	lbs
50 mm Lead	905	1995
80 mm Lead	1555	3428

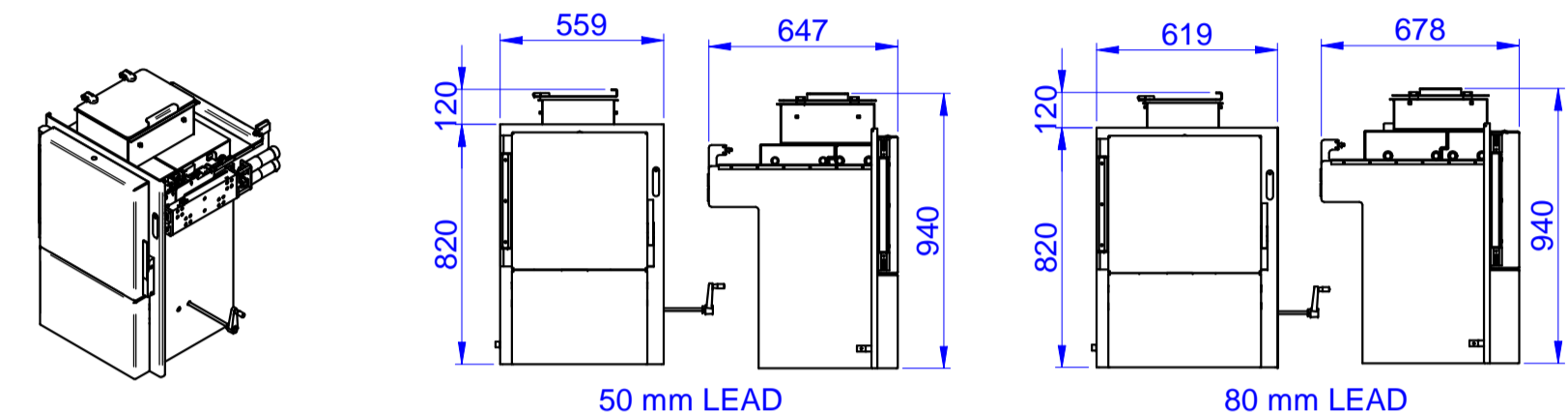

4	WASTE UNIT	
	WEIGHT	
Version	Kg	lbs
10 mm Lead	140	0
30 mm Lead	225	496

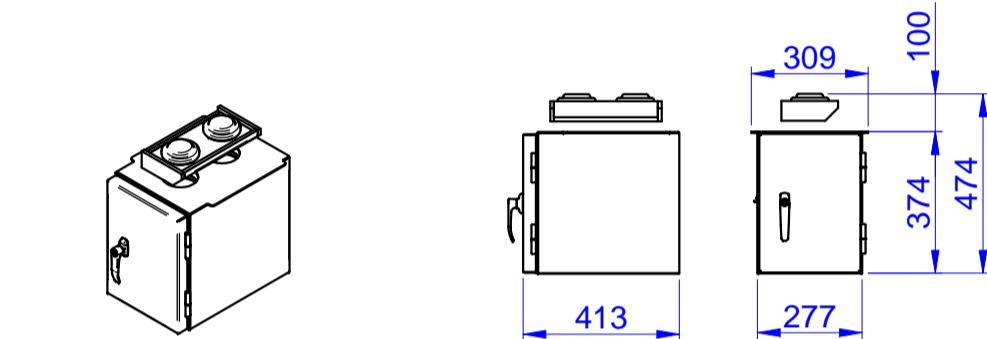

5	IONIZATION CHAMBER	
	WEIGHT	
Version	Kg	lbs
20 mm Lead	105	231
50 mm Lead	270	595

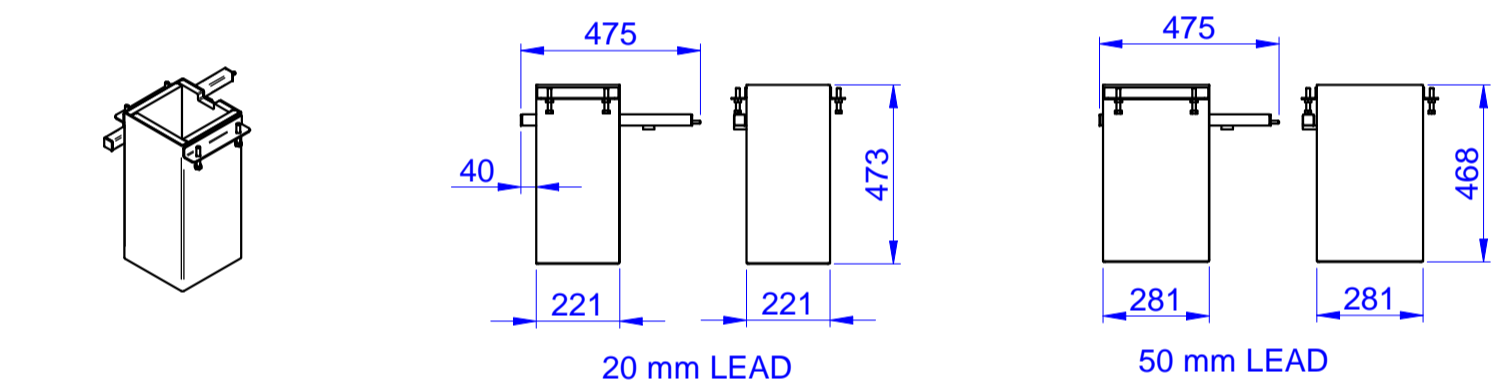

BASIC VERSION

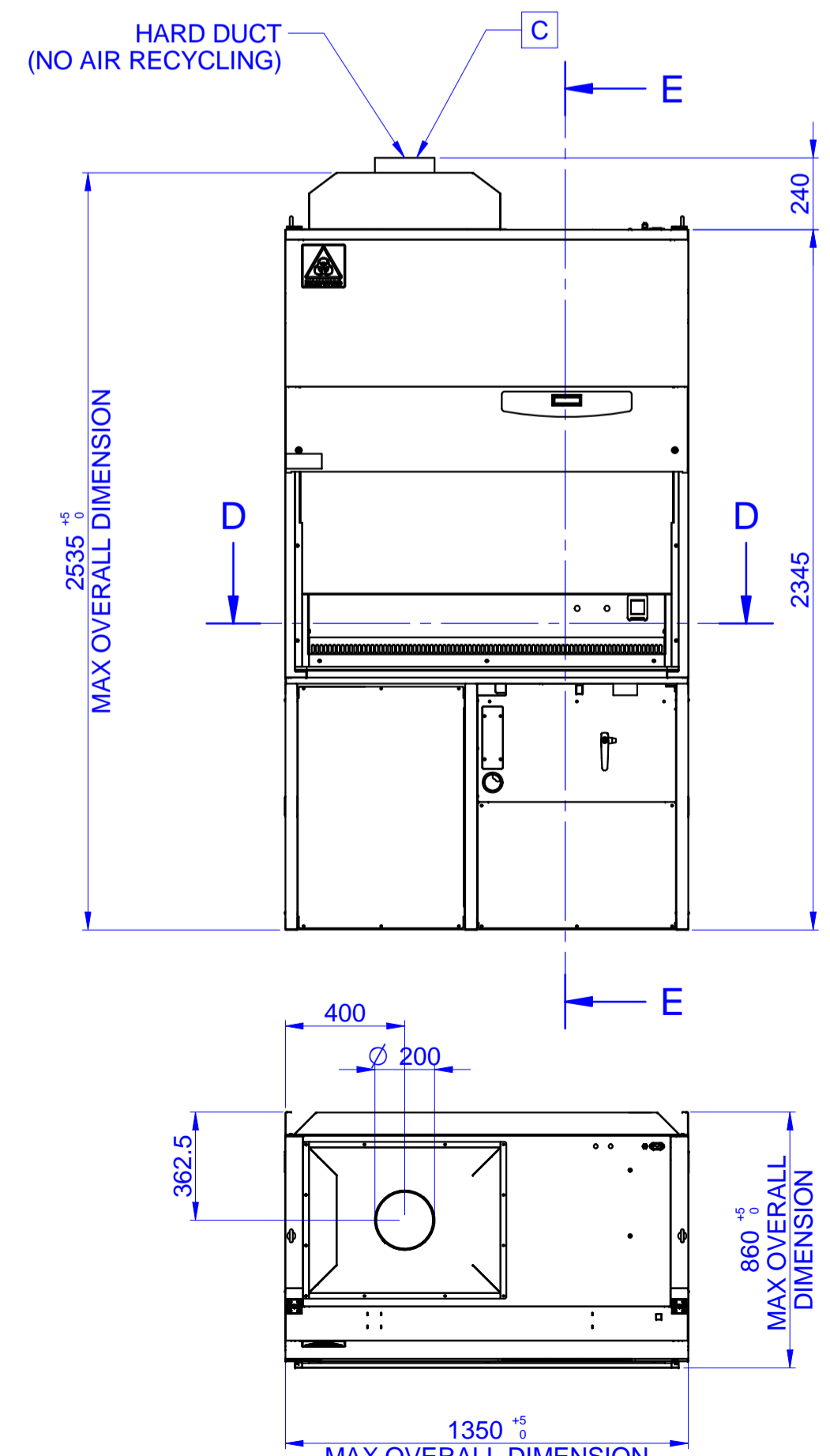
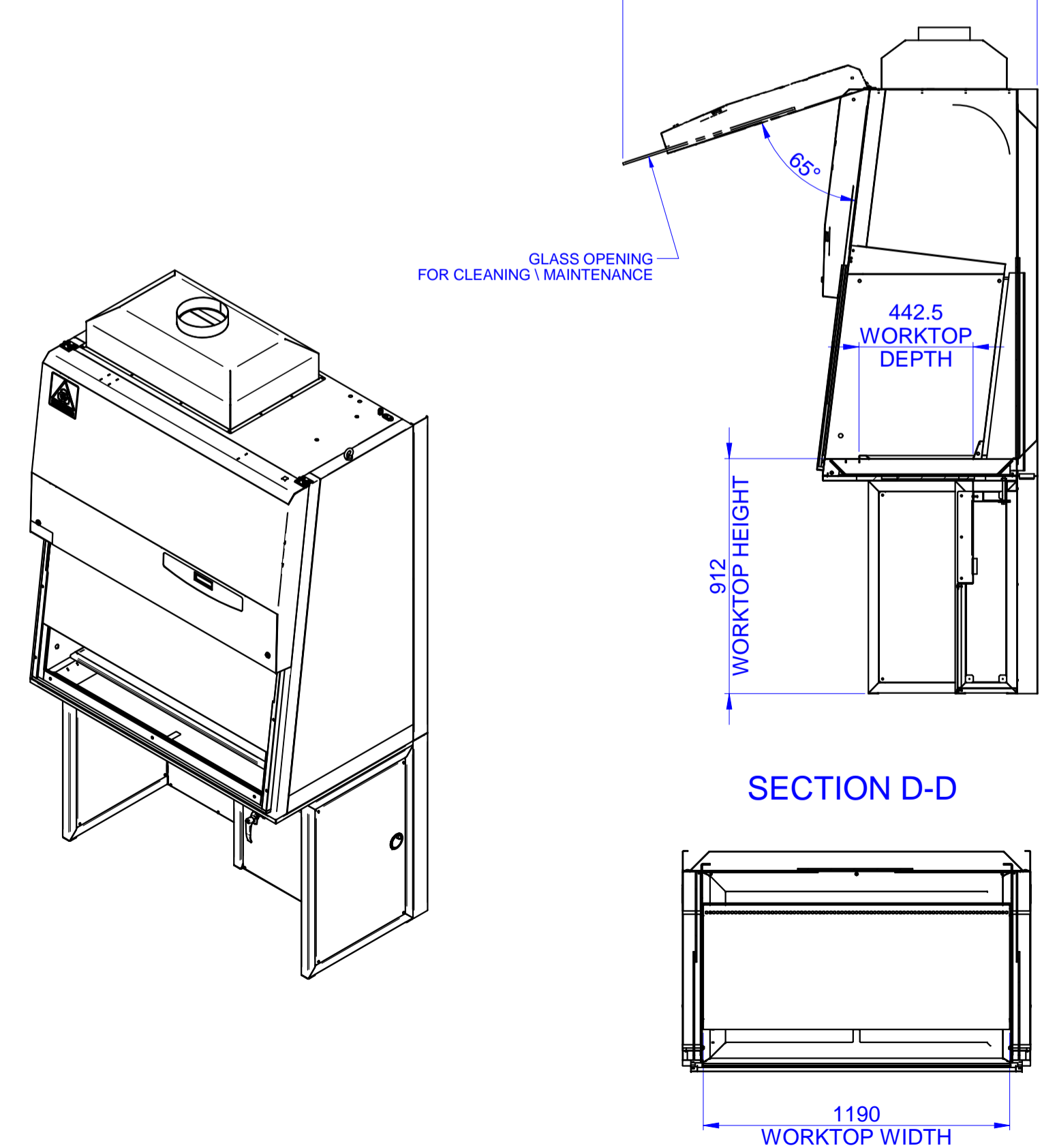

Wall view with electrical connections

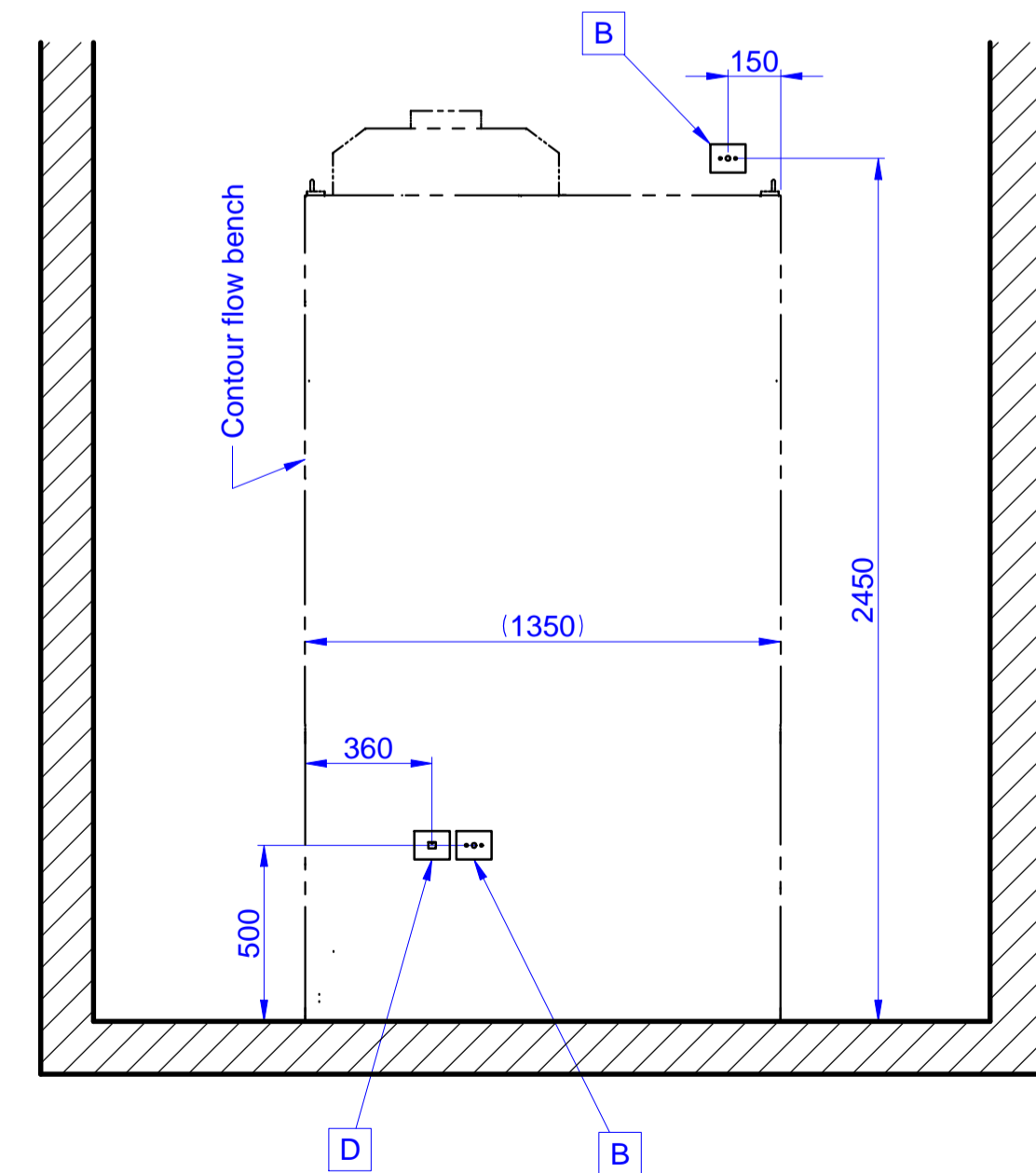

BASIC ITEMS DESCRIPTION

Items	Supply Description	Qty	Std.	Note
B	Electrical Supply	2	CE	230V (1Ph+N+PE) 50/60Hz 16A TN-S
			US	208/120V (2Ph+N+PE(GRD)) 60Hz 15A
C	Exhaust Requirements	1	CE	436 m3/h - connection Ø200mm
			US	
D	Data Connection	1	CE	RJ45 connection
			US	

BH4 HOOD

Version	WEIGHT		DIMENSIONS (W x D x H)	
	Kg	lbs	mm	inches
BASIC without Lead	306	675	1350 x 857 x 1531	53 1/8 x 33 3/4 x 60 1/4
BASIC + 5 mm Lead (optional 1)	521	1149		
BASIC + 10 mm Lead (optional 1)	696	1534		

This drawing is for informational purposes only. The presence and positioning of the optional components, may vary depending on the type of application and the configuration of the product.

DRAWING MADE WITH EUROPEAN VIEWS

		DRAWN BY: User31 DATE: 25/01/2016		APPROVED BY: S. Speronati DATE: 1/1 REV: 0	
Description of the Exponent of Change		Origin Code		DEMO CAPPA BH4-CE	